

IIVI INFRARED

... the world leader in CO₂ laser optics

CO₂ LASER NOZZLES AND ACCESSORIES

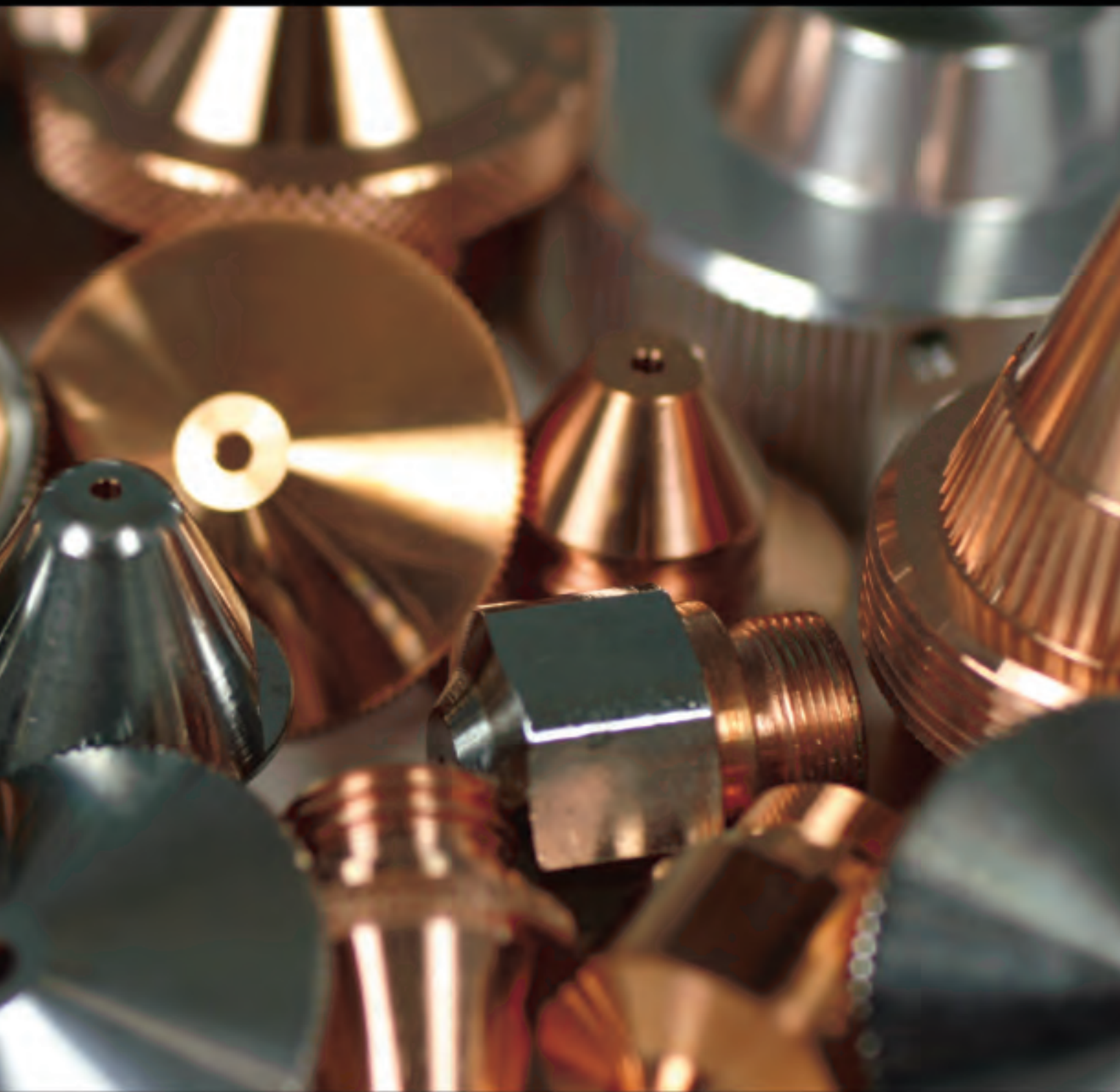

FOR ALL MAJOR OEM LASER MODELS

888.558.1504 (toll-free) • 724.352.1504 (phone) • 724.352.4980 (fax) • www.iiviiinfrared.com

IIVI

AMADA	1
BEHRENS	8
BYSTRONIC	9
CINCINNATI	16
FINN POWER	17
GHT	20
HAAS	22
HACO	23
LASER LAB	24
LVD	25
MAZAK	27
MESSER GRIESHEIM	41
MITSUBISHI	42
MURATA WIEDEMANN	45
NTC - BEYELER	46
PRECITEC	47
PRIMA INDUSTRIE	59
RASKIN	62
ROUCHAUD	63
SALVAGNINI	64
STRIPPIT	66
TRUMPF	67
VALFIVRE	79



HOW TO ORDER

If you are unsure of what nozzles you need contact our trained staff for assistance.

Customers in the USA and Canada can call toll-free: 888.558.1504.

Customers outside of the USA and Canada can call: 724.352.1504.

Customers in Europe and Asia can also contact a II-VI Subsidiary Office (see back cover for details).

*Contact a II-VI sales representative for 10-pack availability by specific part number.

Catalog revised December 2006 and copyrighted by II-VI Incorporated.

All original equipment manufacturer's names, drawings, colors, trademarks and part numbers are used for identification purposes only, and we are in no way implying that any of our products are original equipment parts. All parts advertised for sale in this catalog are made for and/or by II-VI Incorporated.

This page intentionally left blank.

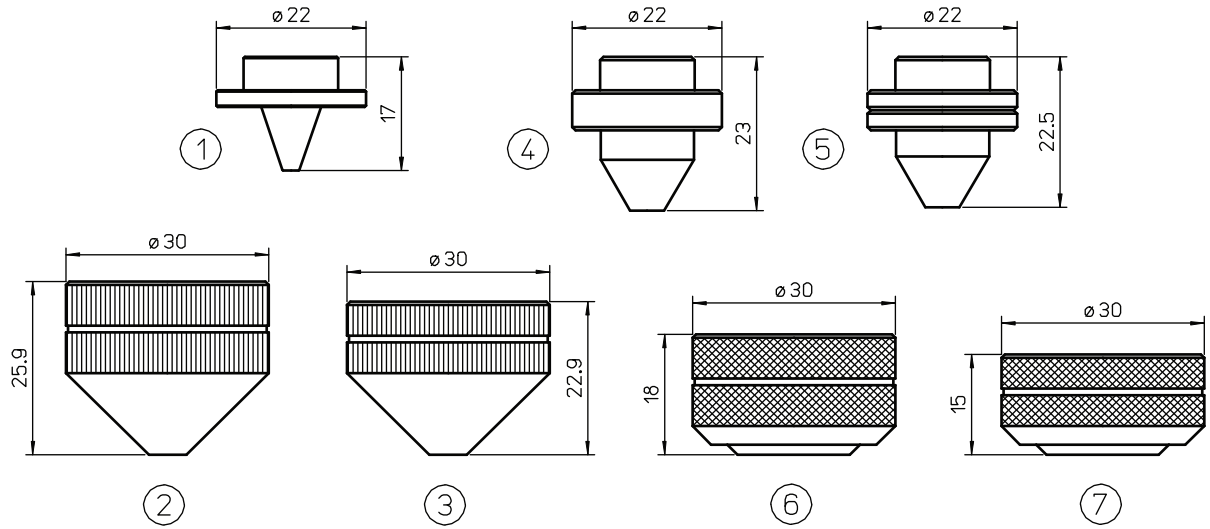

POS	II-VI p/n	OEM p/n	DESCRIPTION
1	L288	W390	MITSUBISHI® DOUBLE NOZZLE INSERT 4 HOLE
	L835	W270-6	MITSUBISHI® DOUBLE NOZZLE INSERT 6 HOLE
	L280	W270	MITSUBISHI® DOUBLE NOZZLE INSERT 8 HOLE
	L289	W387	MITSUBISHI® DOUBLE NOZZLE INSERT 12 HOLE
	L290	W388	MITSUBISHI® DOUBLE NOZZLE INSERT 16 HOLE
	L836	W389	MITSUBISHI® DOUBLE NOZZLE INSERT 20 HOLE
	L291	W515	MITSUBISHI® DOUBLE NOZZLE INSERT 24 HOLE
2	AL65	W269	MITSUBISHI® SHIELD CUP
3	AL238	P0593-860-00001	MITSUBISHI® SHIELD CUP SHORT
4	L354		MITSUBISHI® NOZZLE Ø 1.0
	L363	W777	MITSUBISHI® NOZZLE Ø 1.2
	L355	W266	MITSUBISHI® NOZZLE Ø 1.5
	L356	W267	MITSUBISHI® NOZZLE Ø 2.0
	L357	W776	MITSUBISHI® NOZZLE Ø 2.5
	L358	W268	MITSUBISHI® NOZZLE Ø 3.0
	L359	W268-3.5	MITSUBISHI® NOZZLE Ø 3.5
5	L965		MITSUBISHI® NOZZLE Ø1.0
	L966		MITSUBISHI® NOZZLE Ø 1.2
	L967		MITSUBISHI® NOZZLE Ø 1.5
	L968		MITSUBISHI® NOZZLE Ø 2.0
	L969		MITSUBISHI® NOZZLE Ø 2.5
6	AL116	W263	MITSUBISHI® NOZZLE NUT
7	AL240		MITSUBISHI® NOZZLE NUT SHORT

REPLACEMENT CO₂ LASER NOZZLES & ACCESSORIES

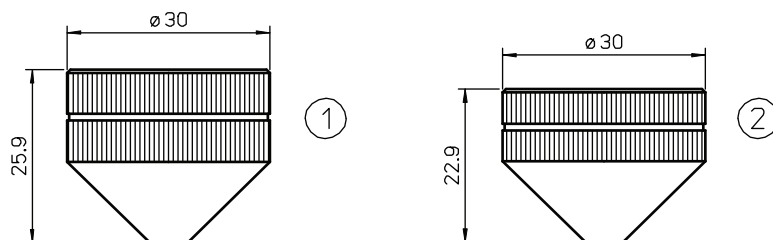

POS	II-VI p/n	OEM p/n	DESCRIPTION
1	L398	W1249	MITSUBISHI® SHIELD NOZZLE Ø 1.0
	L397	W1256	MITSUBISHI® SHIELD NOZZLE Ø 1.2
	L399	W1250	MITSUBISHI® SHIELD NOZZLE Ø 1.5
	L702	W1251	MITSUBISHI® SHIELD NOZZLE Ø 2.0
	L703	W1252	MITSUBISHI® SHIELD NOZZLE Ø 2.5
	L704	W1253	MITSUBISHI® SHIELD NOZZLE Ø 3.0
	L705	W1254	MITSUBISHI® SHIELD NOZZLE Ø 3.5
	L706	W1255	MITSUBISHI® SHIELD NOZZLE Ø 4.0
2	L910	W1626	MITSUBISHI® SHIELD NOZZLE Ø 1.0 SHORT
	L911	W1627	MITSUBISHI® SHIELD NOZZLE Ø 1.2 SHORT
	L912	W1628	MITSUBISHI® SHIELD NOZZLE Ø 1.5 SHORT
	L913	W1629	MITSUBISHI® SHIELD NOZZLE Ø 2.0 SHORT
	L914	W1630	MITSUBISHI® SHIELD NOZZLE Ø 2.5 SHORT
	L915	W1664	MITSUBISHI® SHIELD NOZZLE Ø 3.0 SHORT
	L916	W1665	MITSUBISHI® SHIELD NOZZLE Ø 3.5 SHORT
	L917	W1666	MITSUBISHI® SHIELD NOZZLE Ø 4.0 SHORT

MITSUBISHI

All original equipment manufacturer's names, drawings, colors, trademarks and part numbers are used for identification purposes only, and we are in no way implying that any of our products are original equipment parts. All parts advertised for sale in this catalog are made for and/or by II-VI Incorporated.

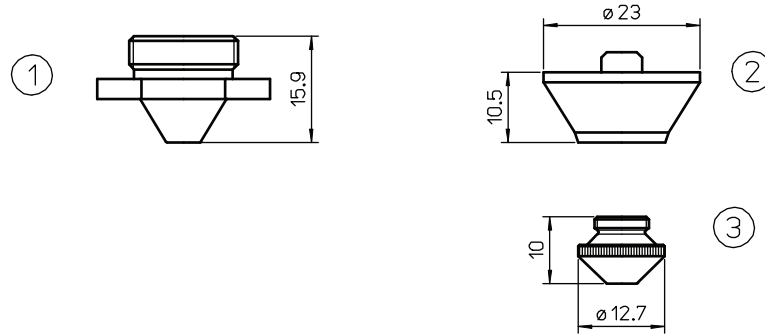

POS	II-VI p/n	OEM p/n	DESCRIPTION
1	L548		MITSUBISHI® NOZZLE Ø 1.0
	L549	W001	MITSUBISHI® NOZZLE Ø 1.5
	L550	W002	MITSUBISHI® NOZZLE Ø 2.0
	L551	W004	MITSUBISHI® NOZZLE Ø 2.5
	L552	W003	MITSUBISHI® NOZZLE Ø 3.0
2	AL138	281079-P0492-430-00003-W149	PRECITEC® ORIG. NOZZLE HOLDER KT M1.5 S F2.5
3	L400	280013-P0492-441-00008	PRECITEC® FP NOZZLE Ø 0.8
	L401	280014-P0492-442-00010-W223	PRECITEC® FP NOZZLE Ø 1.0
	L402	280015-P0492-443-00012	PRECITEC® FP NOZZLE Ø 1.2
	L403	280016-P0492-444-00015-W224	PRECITEC® FP NOZZLE Ø 1.5
	L543	P0492-447-00018	PRECITEC® FP NOZZLE Ø 1.8
	L544	280937-P0492-445-00020-W225	PRECITEC® FP NOZZLE Ø 2.0
	L546	P0492-448-00023	PRECITEC® FP NOZZLE Ø 2.3
	L545	281791-P0492-446-00025-W226	PRECITEC® FP NOZZLE Ø 2.5
	L547		PRECITEC® FP NOZZLE Ø 3.0

This page intentionally left blank.

www.iiviinfrared.com

All original equipment manufacturer's names, drawings, colors, trademarks and part numbers are used for identification purposes only, and we are in no way implying that any of our products are original equipment parts. All parts advertised for sale in this catalog are made for and/or by II-VI Incorporated.

II-VI INFRARED ... the world leader in CO₂ laser optics

FOR ALL OF YOUR REPLACEMENT OPTIC NEEDS

888.558.1504 (toll-free) • 724.352.1504 (phone) • 724.352.4980 (fax) • www.iiviiinfrared.com

II-VI

The advertisement features a collection of laser optics, including several circular lenses with a yellowish-orange tint and a black nozzle with a silver-colored ring. The nozzle has the text "II-VI INFRARED" and "HARRISBURG, PA U.S.A." engraved on it. The background is dark, making the optics stand out.

REPLACEMENT CO₂ LASER NOZZLES & ACCESSORIES

All orders received by II-VI Incorporated ("II-VI") are expressly conditioned upon the following conditions of sale:

1) Acceptance

Any additional or different terms set forth in any purchase order or other communication from Buyer are objected to and not binding upon II-VI unless and until accepted in writing by an authorized representative of II-VI.

2) Standard Warranty

II-VI warrants to the Buyer of each product of II-VI's own manufacture ("Product") that each Product will be free from defects in materials and workmanship subject to the following conditions:

The obligations of II-VI under this Standard Warranty shall be limited to either, at the option of II-VI: (1) the replacement or repair of any Product upon the shipment of such Product, freight prepaid by Buyer to the II-VI factory; or (2) the provision to Buyer of a credit against future purchases in an amount equal to the purchase price of the defective Product.

IN NO EVENT WILL II-VI BE LIABLE FOR ANY INCIDENTAL OR CONSEQUENTIAL DAMAGES OF BUYER. THE FOREGOING REMEDIES ARE THE SOLE AND EXCLUSIVE REMEDY OF BUYER FOR ANY BREACH OF WARRANTY UNDER THIS CONTRACT.

All claims under this Standard Warranty must be made within ONE (1) YEAR after the date on which the Product was delivered to Buyer. In the case of a replacement or repair of a Product, Buyer shall only ship a defective Product to II-VI after an authorized representative of II-VI has provided a Return Authorization (RA) number for such warranty claim. Returns will be subject to a 30% restocking fee.

With respect to such returns, Buyer is solely responsible for properly packaging any Product to be returned to II-VI under this Standard Warranty. Products must be packaged in their original manufacturer's packaging or equivalent. Products must be packaged in separate shipping containers with Return Authorization (RA) numbers clearly marked on the outside of the shipping containers. If there are questions regarding proper packaging and shipping, contact II-VI for guidelines. II-VI will not be responsible for replacing or repairing any Product damaged while in transit to II-VI due to faulty or deficient packaging.

This Standard Warranty shall be void and shall not apply with respect to any Product which, upon inspection by II-VI, shows evidence of damage as a result of abuse, misuse, mishandling, accidental damage, alteration, negligent handling, or improper installation or application, or as a result of alteration or other causes beyond the control of II-VI.

This Standard Warranty shall not apply to goods or parts included in or supplied with Products; such goods or parts carry only such warranties, if any, as are provided by the manufacturers of such goods or parts, which warranties may be more restrictive than the Standard Warranty provided by II-VI.

With respect to any previously-purchased Product, II-VI shall have no obligation to install updates or upgrades to any components in such Product, even if the exclusion of such updates or upgrades of such components renders such Product obsolete when compared to a new Product of a substantially similar type.

THERE ARE NO WARRANTIES THAT EXTEND BEYOND THE DESCRIPTION CONTAINED HEREIN. THIS WARRANTY VOIDS AND EXCLUDES ANY AND ALL OTHER WARRANTIES OR REPRESENTATIONS, WHETHER EXPRESS OR IMPLIED OR ARISING UNDER ANY LAW, RELATING TO THE GOODS, INCLUDING BUT NOT LIMITED TO WARRANTIES OF MERCHANTABILITY AND/OR FITNESS FOR ANY PARTICULAR PURPOSES.

NO PERSON, FIRM, OR CORPORATION IS AUTHORIZED TO ASSUME ON BEHALF OF II-VI ANY ADDITIONAL OBLIGATION OR LIABILITY NOT EXPRESSLY PROVIDED HEREIN, EXCEPT IN A WRITING DULY EXECUTED BY AN OFFICER OF II-VI.

3) Limitation of Liability

In no event shall II-VI be liable for any incidental or consequential damages. The liability of II-VI on any claim of any kind shall in no event exceed the price of the Product which gives rise to the claim. Except as to title, all such liability shall terminate upon expiration of the warranty period of the Product.

The invalidity of any of the previous paragraphs shall not affect the remainder of this paragraph or any other paragraph in this section.

4) Patent Infringement

Buyer shall hold II-VI harmless against any expense or loss resulting from infringement of patents or trademarks arising from compliance with Buyer's designs or specifications.

5) Delivery and Title

Delivery dates are approximate and are based upon prompt receipt of all necessary information from Buyer. Under no circumstances does II-VI guarantee date of shipment.

Unless otherwise specified by II-VI, shipment will be made and title will pass F.O.B. point of shipment. II-VI shall ship Products as it deems appropriate unless instructed otherwise in writing by Buyer.

6) Risk of Loss

Risk of loss or damage shall pass to Buyer upon shipment. Loss or damage that occurs during shipping by a carrier selected by Buyer is Buyer's responsibility.

7) Uncontrollable Delays

II-VI shall not be liable for delivery delays due to causes beyond its reasonable control including, but not limited to, acts of God, acts of Buyer, acts of military authority, governmental priorities, labor strikes, and transportation delays.

8) Financial Conditions

If II-VI determines in good faith that the financial condition of Buyer at any time does not justify the continuation of production or shipment on the terms of payment originally specified, II-VI may require full or partial payment in advance. In the event of Buyer bankruptcy or insolvency, II-VI shall be entitled to cancel any outstanding order and shall receive reimbursement for its cancellation charges.

9) Payment Terms

Unless terms are specifically set forth on the Order Acknowledgement, Buyer shall pay at such time and such terms as specified in II-VI's original invoice. Any quotations shall be valid for the period stated on the quotation.

10) Cancellation

Buyer may not cancel its order after shipment has been made. Buyer may cancel its order prior to shipment only upon written notice and consent of II-VI. If II-VI consents to any such cancellation, Buyer may be required to pay cancellation charges which include lost profits and all expenses incurred in connection with the cancelled order.

11) Jurisdiction

The validity, performance, and all matters relating to the interpretation and effect of this agreement shall be governed by the laws of the Commonwealth of Pennsylvania.

TERMS AND CONDITIONS OF SALE

All original equipment manufacturer's names, drawings, colors, trademarks and part numbers are used for identification purposes only, and we are in no way implying that any of our products are original equipment parts. All parts advertised for sale in this catalog are made for and/or by II-VI Incorporated.

WORLDWIDE SALES OFFICES

To place an order, contact a II-VI sales representative at any of the following locations, or log onto www.iiviinfrared.com/contact for our most complete and up-to-date information.

II-VI INFRARED

375 SAXONBURG BLVD
SAXONBURG, PA 16056
UNITED STATES

888.558.1504 (toll-free in USA)
724.352.1504 (phone)
724.352.4980 (fax)
info@iiviinfrared.com (e-mail)

II-VI WEST

36570 BRIGGS ROAD
MURRIETA, CA 92563
UNITED STATES

800.262.5273 (toll-free in USA)
951.926.7640 (phone)
951.926.1984 (fax)
info@iiviinfrared.com (e-mail)

II-VI BELGIUM NV

BAAIKENSSTRAAT 21/2
B-9240 ZELE
BELGIUM

32 (0) 52 45 86 10 (phone)
32 (0) 52 45 86 11 (fax)
sales@ii-vi.be (e-mail)

II-VI DEUTSCHLAND GmbH

IM TIEFEN SEE 58
D-64293 DARMSTADT
GERMANY

49 6151 880 629 (phone)
49 6151 896 667 (fax)
info@ii-vi.de (e-mail)

II-VI SUISSE S.à.r.l.

MOULIN-DU-CHOC
1122 ROMANEL-SUR-MORGES
SWITZERLAND

41 21 869 02 52 (phone)
41 21 869 93 08 (fax)
info@ii-vi-suisse.ch (e-mail)

II-VI UK LTD.

21 BURLEY ROAD
OAKHAM, RUTLAND
LE15 6DH
ENGLAND

44 1572 771 778 (phone)
44 1572 771 779 (fax)
salesii-vi@oakham.uk.com (e-mail)

II-VI JAPAN

WBG MARIVE EAST 17F
2-6 NAKASE, MIHAMA-KU
CHIBA-SHI, CHIBA 261-7117
JAPAN

81 43297 2693 (phone)
81 43297 3003 (fax)
center@ii-vi.co.jp (e-mail)

II-VI SINGAPORE PTE., LTD.

BLK. 5012, TECH PLACE II
#04-07 & 05-07/12
ANG MO KIO AVE. 5
SINGAPORE 569876

65 6481 8215 (phone)
65 6481 8702 (fax)
info@ii-vi.com.sg (e-mail)

II-VI OPTICS (SUZHOU) CO., LTD.

NO 12, SUTONG ROAD
SUZHOU INDUSTRIAL PARK
SUZHOU, CHINA 215021

86 512 6761 9295 (phone)
86 512 6761 5049 (fax)
twosix@ii-vi.com.cn (e-mail)

www.iiviinfrared.com