

**IIVI** INFRARED

... the world leader in CO<sub>2</sub> laser optics

**CO<sub>2</sub> LASER NOZZLES AND ACCESSORIES**

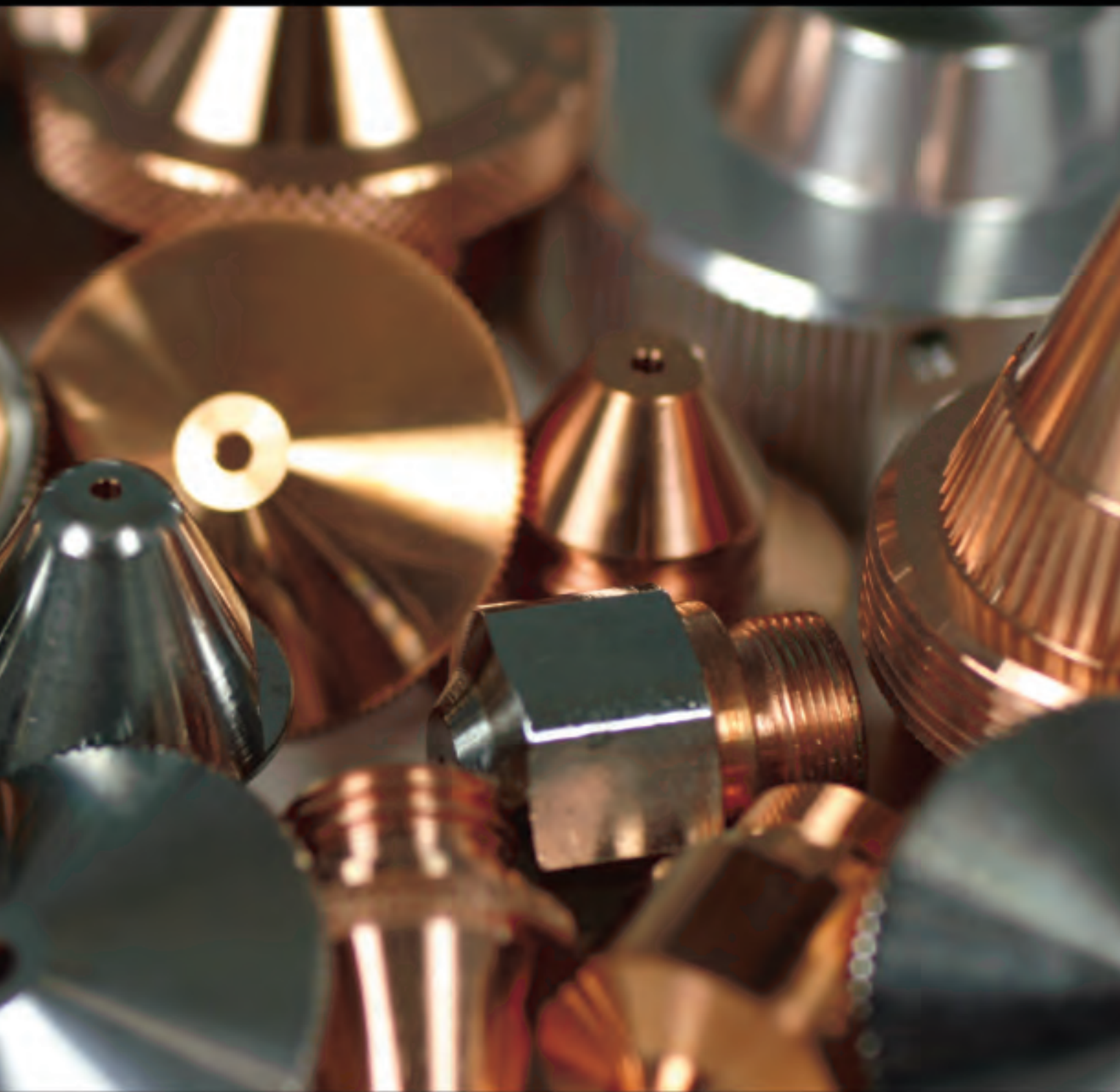

**FOR ALL MAJOR OEM LASER MODELS**

888.558.1504 (toll-free) • 724.352.1504 (phone) • 724.352.4980 (fax) • [www.iiviiinfrared.com](http://www.iiviiinfrared.com)

**IIVI**

<b>AMADA</b>	<b>1</b>
<b>BEHRENS</b>	<b>8</b>
<b>BYSTRONIC</b>	<b>9</b>
<b>CINCINNATI</b>	<b>16</b>
<b>FINN POWER</b>	<b>17</b>
<b>GHT</b>	<b>20</b>
<b>HAAS</b>	<b>22</b>
<b>HACO</b>	<b>23</b>
<b>LASER LAB</b>	<b>24</b>
<b>LVD</b>	<b>25</b>
<b>MAZAK</b>	<b>27</b>
<b>MESSER GRIESHEIM</b>	<b>41</b>
<b>MITSUBISHI</b>	<b>42</b>
<b>MURATA WIEDEMANN</b>	<b>45</b>
<b>NTC - BEYELER</b>	<b>46</b>
<b>PRECITEC</b>	<b>47</b>
<b>PRIMA INDUSTRIE</b>	<b>59</b>
<b>RASKIN</b>	<b>62</b>
<b>ROUCHAUD</b>	<b>63</b>
<b>SALVAGNINI</b>	<b>64</b>
<b>STRIPPIT</b>	<b>66</b>
<b>TRUMPF</b>	<b>67</b>
<b>VALFIVRE</b>	<b>79</b>



## HOW TO ORDER

If you are unsure of what nozzles you need contact our trained staff for assistance.

Customers in the USA and Canada can call toll-free: 888.558.1504.

Customers outside of the USA and Canada can call: 724.352.1504.

Customers in Europe and Asia can also contact a II-VI Subsidiary Office (see back cover for details).

\*Contact a II-VI sales representative for 10-pack availability by specific part number.

Catalog revised December 2006 and copyrighted by II-VI Incorporated.

All original equipment manufacturer's names, drawings, colors, trademarks and part numbers are used for identification purposes only, and we are in no way implying that any of our products are original equipment parts. All parts advertised for sale in this catalog are made for and/or by II-VI Incorporated.

# REPLACEMENT CO<sub>2</sub> LASER NOZZLES & ACCESSORIES

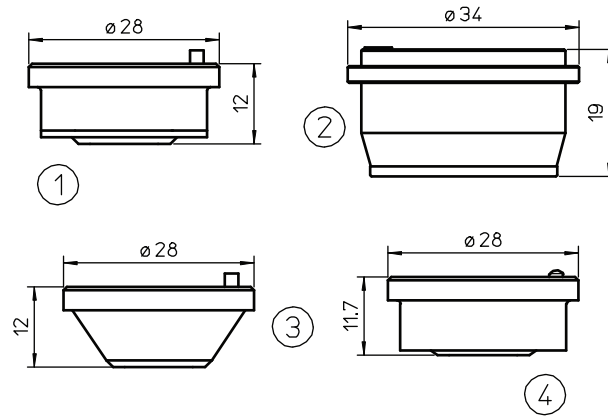

POS	II-VI p/n	OEM p/n	DESCRIPTION
1	AL23	281330-P0571-260-00001	PRECITEC® ORIG. NOZZLE HOLDER KT B2
	AL109	281330-P0571-260-00001	PRECITEC® NOZZLE HOLDER KT B2 - 281330
2	AL228		CR® CERAMIC PART
3	AL140	281795-P0571-255-00001	PRECITEC® ORIG. NOZZLE HOLDER KT B2" H
4	AL141	281518-PO571-265-00001	PRECITEC® ORIG. NOZZLE HOLDER IT B2" Z

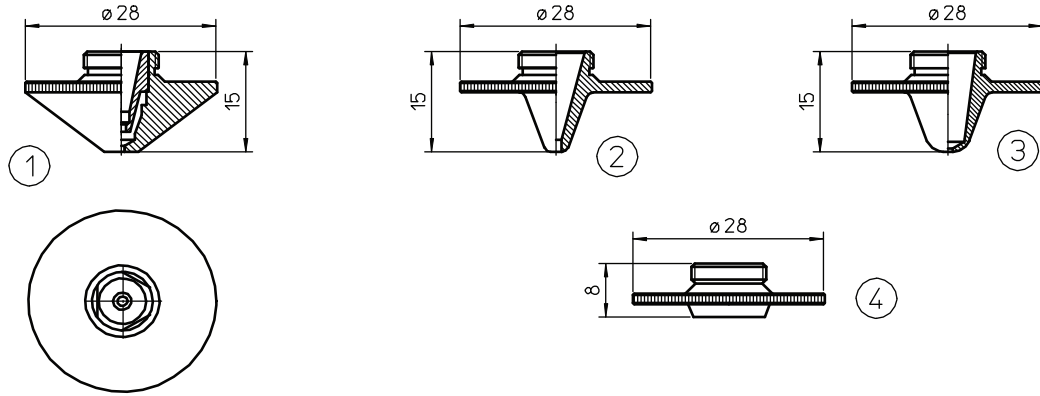

POS	II-VI p/n	OEM p/n	DESCRIPTION
1	L660		PRECITEC® NOZZLE Ø 1.0 W/I
	L661		PRECITEC® NOZZLE Ø 1.25 W/I
	L662		PRECITEC® NOZZLE Ø 1.5 W/I
	L663		PRECITEC® NOZZLE Ø 1.8 W/I
	L664		PRECITEC® NOZZLE Ø 2.0 W/I
	L665		PRECITEC® NOZZLE Ø 2.3 W/I
	L666		PRECITEC® NOZZLE Ø 2.5 W/I
	L667		PRECITEC® NOZZLE Ø 3.0 W/I
	L668		PRECITEC® NOZZLE Ø 3.5 W/I
	L660X		PRECITEC® NOZZLE Ø 1.0 CP W/I
	L661X		PRECITEC® NOZZLE Ø 1.25 CP W/I
	L662X		PRECITEC® NOZZLE Ø 1.5 CP W/I
	L663X		PRECITEC® NOZZLE Ø 1.8 CP W/I
	L664X		PRECITEC® NOZZLE Ø 2.0 CP W/I
	L665X		PRECITEC® NOZZLE Ø 2.3 CP W/I
	L666X		PRECITEC® NOZZLE Ø 2.5 CP W/I
	L667X		PRECITEC® NOZZLE Ø 3.0 CP W/I
L668X		PRECITEC® NOZZLE Ø 3.5 CP W/I	
2	L738		PRECITEC® NOZZLE Ø 1.0 HD
	L739		PRECITEC® NOZZLE Ø 1.25 HD
	L740		PRECITEC® NOZZLE Ø 1.5 HD
3	L792		PRECITEC® NOZZLE Ø 0.8
	L793		PRECITEC® NOZZLE Ø 1.0
	L794		PRECITEC® NOZZLE Ø 1.25
	L742		PRECITEC® NOZZLE Ø 1.5
	L743		PRECITEC® NOZZLE Ø 1.8
	L744		PRECITEC® NOZZLE Ø 2.0
4	AL43		PRECITEC® ADAPTER FOR TRUMPF® NOZZLE

# REPLACEMENT CO<sub>2</sub> LASER NOZZLES & ACCESSORIES

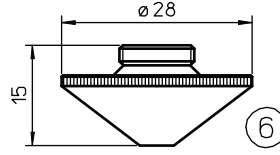
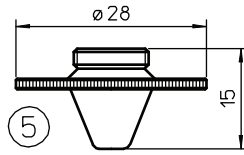

POS	II-VI p/n	OEM p/n	DESCRIPTION
5	L247	281590-P0591-569-00008	PRECITEC® NOZZLE Ø 0.8
	L162	281331-P0591-561-00010	PRECITEC® NOZZLE Ø 1.0
	L130	281351-P0591-562-00012	PRECITEC® NOZZLE Ø 1.25
	L131	281352-P0591-563-00015	PRECITEC® NOZZLE Ø 1.5
	L248		PRECITEC® NOZZLE Ø 1.7
	L153	281352-P0591-564-00018	PRECITEC® NOZZLE Ø 1.8
	L132	281354-P591-565-00020	PRECITEC® NOZZLE Ø 2.0
	L154		PRECITEC® NOZZLE Ø 2.3
	L155	281591-P0591-566-00025	PRECITEC® NOZZLE Ø 2.5
	L156		PRECITEC® NOZZLE Ø 3.0
	L247X	281590-P0591-569-00008	PRECITEC® NOZZLE Ø 0.8 CP
	L162X	281331-P0591-561-00010	PRECITEC® NOZZLE Ø 1.0 CP
	L130X	281351-P0591-562-00012	PRECITEC® NOZZLE Ø 1.25 CP
	L131X	281352-P0591-563-00015	PRECITEC® NOZZLE Ø 1.5 CP
	L248X		PRECITEC® NOZZLE Ø 1.7 CP
	L153X	281352-P0591-564-00018	PRECITEC® NOZZLE Ø 1.8 CP
	L132X	281354-P591-565-00020	PRECITEC® NOZZLE Ø 2.0 CP
	L154X		PRECITEC® NOZZLE Ø 2.3 CP
L155X	281591-P0591-566-00025	PRECITEC® NOZZLE Ø 2.5 CP	
L156X		PRECITEC® NOZZLE Ø 3.0 CP	
6	L234	281548-P0591-571-00010	PRECITEC® NOZZLE Ø 1.0 HD
	L235	281549-P0591-572-00012	PRECITEC® NOZZLE Ø 1.25 HD
	L236	281463-P0591-573-00015	PRECITEC® NOZZLE Ø 1.5 HD
	L237		PRECITEC® NOZZLE Ø 1.8 HD
	L238	281550-P0591-575-00020	PRECITEC® NOZZLE Ø 2.0 HD
	L239		PRECITEC® NOZZLE Ø 2.3 HD
	L240	281551-P0591-576-00025	PRECITEC® NOZZLE Ø 2.5 HD
	L241		PRECITEC® NOZZLE Ø 3.0 HD
	L234X	281548-P0591-571-00010	PRECITEC® NOZZLE Ø 1.0 HD CP
	L235X	281549-P0591-572-00012	PRECITEC® NOZZLE Ø 1.25 HD CP
	L236X	281463-P0591-573-00015	PRECITEC® NOZZLE Ø 1.5 HD CP
	L237X		PRECITEC® NOZZLE Ø 1.8 HD CP
	L238X	281550-P0591-575-00020	PRECITEC® NOZZLE Ø 2.0 HD CP
	L239X		PRECITEC® NOZZLE Ø 2.3 HD CP
	L240X	281551-P0591-576-00025	PRECITEC® NOZZLE Ø 2.5 HD CP
	L241X		PRECITEC® NOZZLE Ø 3.0 HD CP

PRECITEC

All original equipment manufacturer's names, drawings, colors, trademarks and part numbers are used for identification purposes only, and we are in no way implying that any of our products are original equipment parts. All parts advertised for sale in this catalog are made for and/or by II-VI Incorporated.

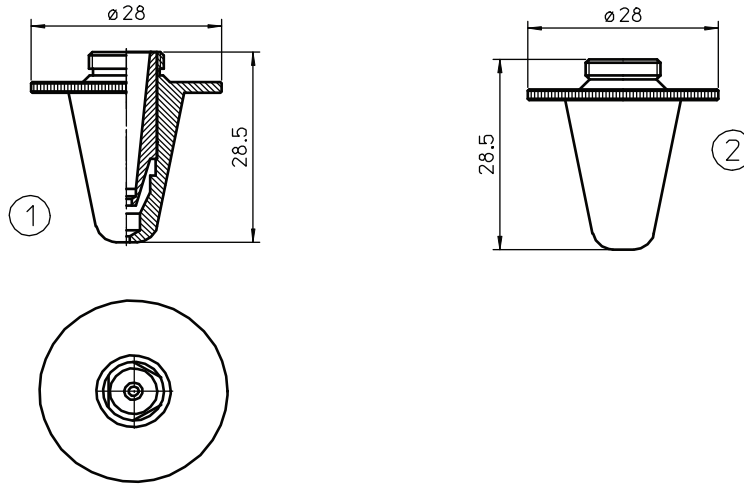

POS	II-VI p/n	OEM p/n	DESCRIPTION
1	L680		PRECITEC® NOZZLE Ø 1.0 LONG W/I
	L681		PRECITEC® NOZZLE Ø 1.25 LONG W/I
	L682		PRECITEC® NOZZLE Ø 1.5 LONG W/I
	L683		PRECITEC® NOZZLE Ø 1.8 LONG W/I
	L684		PRECITEC® NOZZLE Ø 2.0 LONG W/I
	L685		PRECITEC® NOZZLE Ø 2.3 LONG W/I
	L686		PRECITEC® NOZZLE Ø 2.5 LONG W/I
	L687		PRECITEC® NOZZLE Ø 3.0 LONG W/I
	L688		PRECITEC® NOZZLE Ø 3.5 LONG W/I
2	L308	P0573-563-00010	PRECITEC® NOZZLE Ø 1.0 LONGED
	L307	P0573-563-00012	PRECITEC® NOZZLE Ø 1.25 LONGED
	L382	P0573-563-00015	PRECITEC® NOZZLE Ø 1.5 LONGED
	L383		PRECITEC® NOZZLE Ø 1.8 LONGED
	L437	P0573-564-00020	PRECITEC® NOZZLE Ø 2.0 LONGED
	L438	P0573-565-00023	PRECITEC® NOZZLE Ø 2.3 LONGED
	L439	P0573-566-00025	PRECITEC® NOZZLE Ø 2.5 LONGED
	L440		PRECITEC® NOZZLE Ø 3.0 LONGED

# REPLACEMENT CO<sub>2</sub> LASER NOZZLES & ACCESSORIES

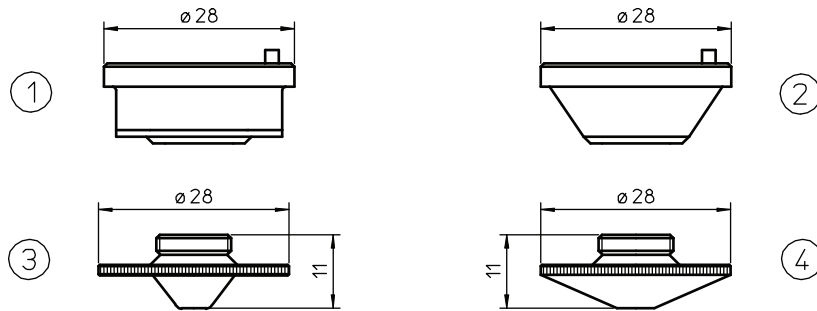

POS	II-VI p/n	OEM p/n	DESCRIPTION
1	AL23	281330-P0571-260-00001	PRECITEC® ORIG. NOZZLE HOLDER KT B2
	AL109	281330-P0571-260-00001	PRECITEC® NOZZLE HOLDER KT B2 - 281330
2	AL140	281795-P0571-255-00001	PRECITEC® ORIG. NOZZLE HOLDER KT B2" H
3	L410	281340-P0571-281-00010	PRECITEC® NOZZLE Ø 1.0
	L411	281341-P0571-282-00012	PRECITEC® NOZZLE Ø 1.2
	L412	281342-P0571-283-00015	PRECITEC® NOZZLE Ø 1.5
	L413	281342-P0571-284-00018	PRECITEC® NOZZLE Ø 1.8
	L414	281343-P0571-285-00020	PRECITEC® NOZZLE Ø 2.0
	L415	281344-P0571-286-00025	PRECITEC® NOZZLE Ø 2.5
4	L465	281599-P0571-291-00010	PRECITEC® NOZZLE Ø 1.0
	L466	P0571-292-00012	PRECITEC® NOZZLE Ø 1.2
	L467	281570-P0571-293-00015	PRECITEC® NOZZLE Ø 1.5
	L468		PRECITEC® NOZZLE Ø 1.8
	L469	281571-P0571-295-00020	PRECITEC® NOZZLE Ø 2.0
	L470	281572-P0571-297-00025	PRECITEC® NOZZLE Ø 2.5

PRECITEC

All original equipment manufacturer's names, drawings, colors, trademarks and part numbers are used for identification purposes only, and we are in no way implying that any of our products are original equipment parts. All parts advertised for sale in this catalog are made for and/or by II-VI Incorporated.

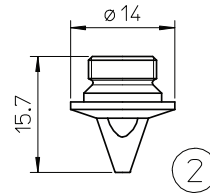
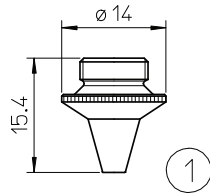

POS	II-VI p/n	OEM p/n	DESCRIPTION

### AKK52 - AKH27 - YH27 - YR30 SENSOR SYSTEM

1	L405	281813-P0589-424-00008	PRECITEC® NOZZLE Ø 0.8
	L406	281789-P0589-426-00010	PRECITEC® NOZZLE Ø 1.0
	L404	281561 - 778550	PRECITEC® NOZZLE Ø 1.2
	L407	281814 - 149957	PRECITEC® NOZZLE Ø 1.5
	L408	P0589-428-00020	PRECITEC® NOZZLE Ø 2.0
	L405X	281813-P0589-424-00008	PRECITEC® NOZZLE Ø 0.8 CP
	L406X	281789-P0589-426-00010	PRECITEC® NOZZLE Ø 1.0 CP
	L404X	281561 - 778550	PRECITEC® NOZZLE Ø 1.2 CP
	L407X	281814 - 149957	PRECITEC® NOZZLE Ø 1.5 CP
	L408X	P0589-428-00020	PRECITEC® NOZZLE Ø 2.0 CP

### YK52 SENSOR SYSTEM

2	L800	281498-PO587-722-00010	PRECITEC® NOZZLE Ø 1.0
	L801	PO587-723-00012	PRECITEC® NOZZLE Ø 1.2
	L802	281497-PO587-721-00015	PRECITEC® NOZZLE Ø 1.5
	L803	281516-PO587-737-00018	PRECITEC® NOZZLE Ø 1.8
	L804	281567-PO587-771-00020	PRECITEC® NOZZLE Ø 2.0
	L805	PO587-772-00025	PRECITEC® NOZZLE Ø 2.5

# REPLACEMENT CO<sub>2</sub> LASER NOZZLES & ACCESSORIES

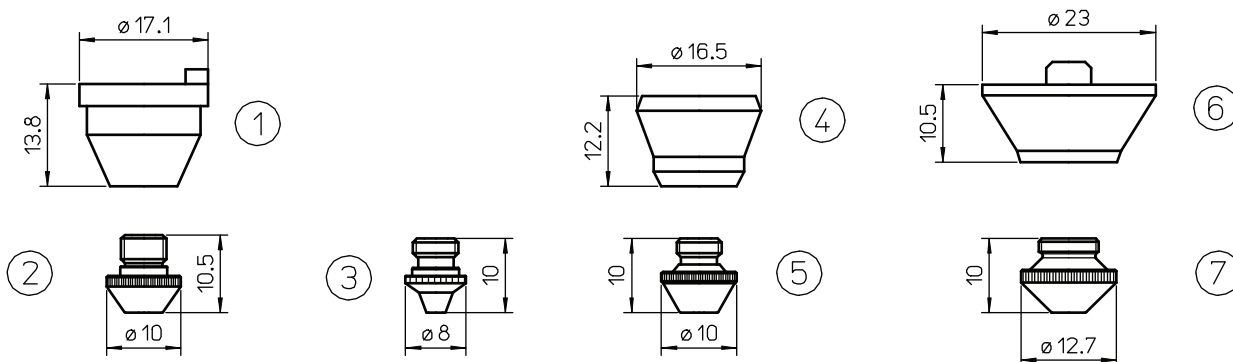

POS	II-VI p/n	OEM p/n	DESCRIPTION
<b>5" KN SENSOR SYSTEM</b>			
1	AL53	280408-P0494-752-00001	TRUMPF® ORIG. NOZZLE HOLDER KT M1.5 KN
2	L292	280551-P0494-853-00010	PRECITEC® NOZZLE Ø 1.0
	L293	280552-P0494-854-00012	PRECITEC® NOZZLE Ø 1.2
	L294	280553-P0494-855-00015	PRECITEC® NOZZLE Ø 1.5
3	L1055	280943-P0494-787-00010	PRECITEC® NOZZLE Ø 1.0 KN TAK
	L1056	280942-P0494-788-00012	PRECITEC® NOZZLE Ø 1.2 KN TAK
	L1057	280941-P0494-789-00015	PRECITEC® NOZZLE Ø 1.5 KN TAK
	L1058		PRECITEC® NOZZLE Ø 1.8
	L1059		PRECITEC® NOZZLE Ø 2.0
<b>5" K SENSOR SYSTEM</b>			
4	AL67	280040 - P0492-752-00001	PRECITEC® ORIG. NOZZLE HOLDER KT M1.5K
5	L350	280048-P0492-853-00010	PRECITEC® NOZZLE Ø 1.0
	L351	280049-P0492-854-00012	PRECITEC® NOZZLE Ø 1.2
	L352	280050-P0492-855-00015	PRECITEC® NOZZLE Ø 1.5
	L353	280050	PRECITEC® NOZZLE Ø 2.0
<b>2.5" CM SENSOR SYSTEM</b>			
6	AL138	281079-P0492-430-00003-W149	PRECITEC® ORIG. NOZZLE HOLDER KT M1.5 S F2.5
7	L400	280013-P0492-441-00008	PRECITEC® FP NOZZLE Ø 0.8
	L401	280014-P0492-442-00010-W223	PRECITEC® FP NOZZLE Ø 1.0
	L402	280015-P0492-443-00012	PRECITEC® FP NOZZLE Ø 1.2
	L403	280016-P0492-444-00015-W224	PRECITEC® FP NOZZLE Ø 1.5
	L543	P0492-447-00018	PRECITEC® FP NOZZLE Ø 1.8
	L544	280937-P0492-445-00020-W225	PRECITEC® FP NOZZLE Ø 2.0
	L546	P0492-448-00023	PRECITEC® FP NOZZLE Ø 2.3
	L545	281791-P0492-446-00025-W226	PRECITEC® FP NOZZLE Ø 2.5
	L547		PRECITEC® FP NOZZLE Ø 3.0

All original equipment manufacturer's names, drawings, colors, trademarks and part numbers are used for identification purposes only, and we are in no way implying that any of our products are original equipment parts. All parts advertised for sale in this catalog are made for and/or by II-VI Incorporated.

Mazak® 3D - Precitec® 5"C/MG - 5"H/MG

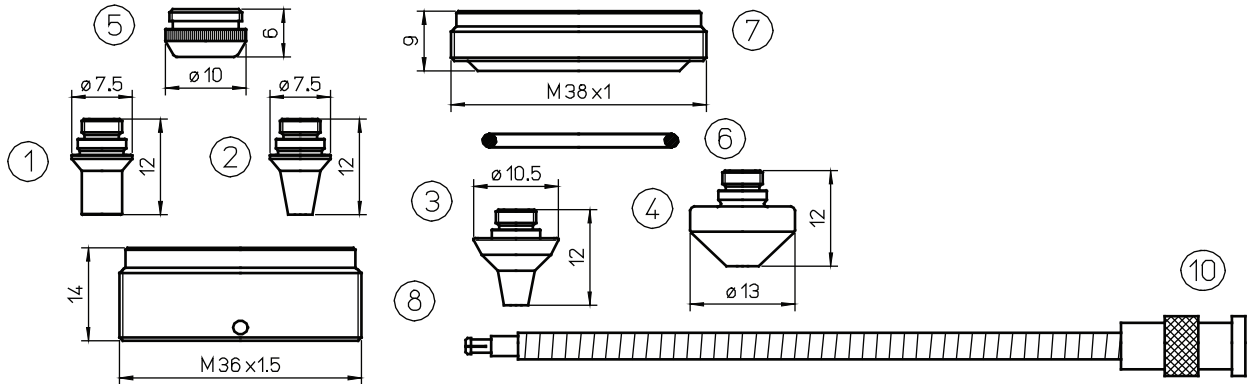

POS	II-VI p/n	OEM p/n	DESCRIPTION
1	L480	281005-P0352-323-00010	MAZAK® NOZZLE Ø 1.0 ZK
	L481	281034-P0352-324-00012	MAZAK® NOZZLE Ø 1.2 ZK
	L482	281013-P0352-325-00015	MAZAK® NOZZLE Ø 1.5 ZK
	L483	280899-P0352-326-00018	MAZAK® NOZZLE Ø 1.8 ZK
	L484	350044.3-P0352-327-00020	MAZAK® NOZZLE Ø 2.0 ZK
2	L486	281006-P0352-333-00010	MAZAK® NOZZLE Ø 1.0 KK
	L487	281030-P0352.334.00012	MAZAK® NOZZLE Ø 1.2 KK
	L488	281031-P0352.335.00015	MAZAK® NOZZLE Ø 1.5 KK
	L489	280898-P0352.336.00018	MAZAK® NOZZLE Ø 1.8 KK
	L490	P0352.336.00020	MAZAK® NOZZLE Ø 2.0 KK
3	L554	46713300290-10	MAZAK® NOZZLE 3D Ø 1.0
	L555	46713300290-12	MAZAK® NOZZLE 3D Ø 1.2
	L556	46713300290-15-P0352-381-00015	MAZAK® NOZZLE 3D Ø 1.5
	L557		MAZAK® NOZZLE 3D Ø 1.8
	L558	46713300310-P0352-382-00020	MAZAK® NOZZLE 3D Ø 2.0
	L560	46713300280-25	MAZAK® NOZZLE 3D Ø 2.5
	L563	46713300280-30	MAZAK® NOZZLE 3D Ø 3.0
	L564	46713300280-35	MAZAK® NOZZLE 3D Ø 3.5
4	L576		MAZAK® NOZZLE Ø INT 1.0 EST 13
	L577	46713300310	MAZAK® NOZZLE Ø INT 1.2 EST 13
	L578	P0352-386-00015	MAZAK® NOZZLE Ø INT 1.5 EST 13
	L579		MAZAK® NOZZLE Ø INT 1.8 EST 13
	L580	46713300300-P0352-387-00020	MAZAK® NOZZLE Ø INT 2.0 EST 13
	L581	46713300300-25	MAZAK® NOZZLE Ø INT 2.5 EST 13
	L582	46713300300-30	MAZAK® NOZZLE Ø INT 3.0 EST 13
	5	AL160	46713300321-P0352-311-00001
6	AL94	71366453	AMADA® O'RING FOR NOZZLE OUTER-10 PCS
7	AL198	PO492-702-00001 - 49270200001	PRECITEC® INSULATING RING - plastic
8	AL218	46713330200	MAZAK® 5-AXIS INSULATOR
10	AL204	PO360-100-00500	PRECITEC® ORIG SENSOR CABLE KE 500 Z

# REPLACEMENT CO<sub>2</sub> LASER NOZZLES & ACCESSORIES

5"DX - 5"DXN PRECITEC® SENSOR SYSTEM

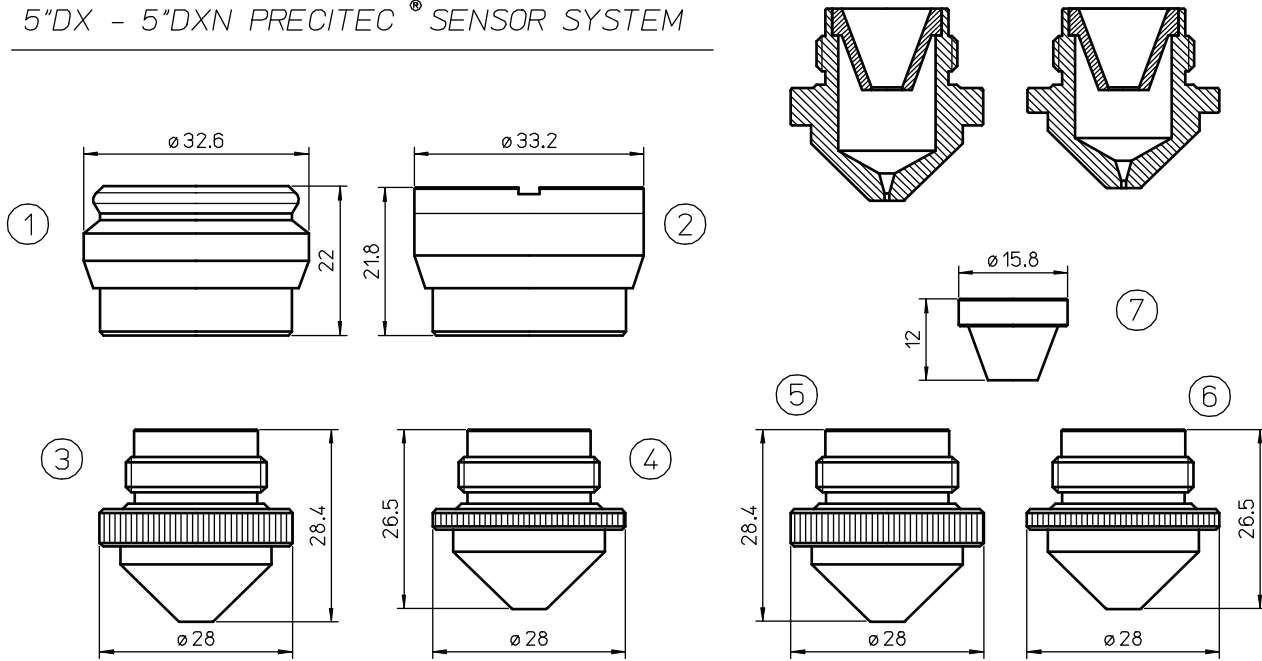

POS	II-VI p/n	OEM p/n	DESCRIPTION
1	AL35	280831-P0492-622-00002	PRECITEC® ORIG. NOZ.HOLDER KT M1.5"DX P0492-622-00002
2	AL40	280565-P0497-605-00001	PRECITEC® ORIG. NOZZLE HOLDER KT M1.5"DXN P0497-605-00001
3	L87		ADIGE S.® NOZZLE Ø 0.8
	L10		ADIGE S.® NOZZLE Ø 1.25
	L90		ADIGE S.® NOZZLE Ø 1.5
4	L40		ADIGE S.® NOZZLE Ø 1.5 HD
	L186		ADIGE S.® NOZZLE Ø 1.8 HD
5	L187		ADIGE S.® NOZZLE Ø 0.8
	L188		ADIGE S.® NOZZLE Ø 1.25
	L189		ADIGE S.® NOZZLE Ø 1.5
6	L190		ADIGE S.® NOZZLE Ø 1.5
	L191		ADIGE S.® NOZZLE Ø 1.8
7	L157		LVD® INNER NOZZLE

All original equipment manufacturer's names, drawings, colors, trademarks and part numbers are used for identification purposes only, and we are in no way implying that any of our products are original equipment parts. All parts advertised for sale in this catalog are made for and/or by II-VI Incorporated.

PRECITEC

## 5" DXN - 5" DL SENSOR SYSTEM

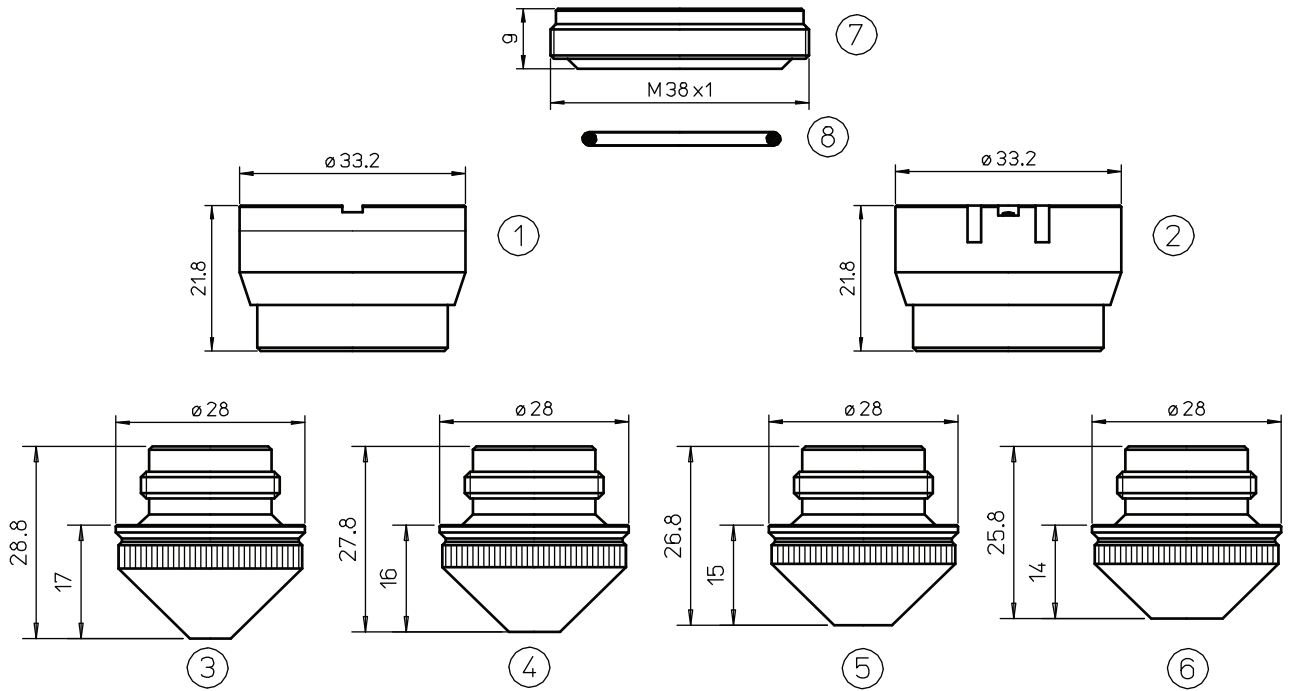

POS	II-VI p/n	OEM p/n	DESCRIPTION
1	AL40	280565-P0497-605-00001	PRECITEC® ORIG. NOZZLE HOLDER KT M1.5"DXN P0497-605-00001
2	AL130	281146-PO380-211-00001	PRECITEC® ORIG. NOZZLE HOLDER IT M1.5" DZ 3164010008
	AL130/S	281146-PO380-211-00001	PRECITEC® NOZZLE HOLDER IT M1.5" DZ 3164010008
3	L365	280029-P0492-628-00010	PRECITEC® NOZZLE Ø 1.0
	L366	280030-P0492-629-00012	PRECITEC® NOZZLE Ø 1.2
4	L367	280028-P0492-627-00015	PRECITEC® NOZZLE Ø 1.5
5	L368	281384-P0492-630-00017	PRECITEC® NOZZLE Ø 1.7
	L369	280027-P0492-626-00020	PRECITEC® NOZZLE Ø 2.0
6	L370	280026-P0492-625-00025	PRECITEC® NOZZLE Ø 2.5
7	AL201	PO492-702-00002	PRECITEC® INSULATING RING
8	AL94	71366453	AMADA® O'RING FOR NOZZLE OUTER-10 PCS

# REPLACEMENT CO<sub>2</sub> LASER NOZZLES & ACCESSORIES

5"DX e 5"DXN PRECITEC® SENSOR SYSTEM

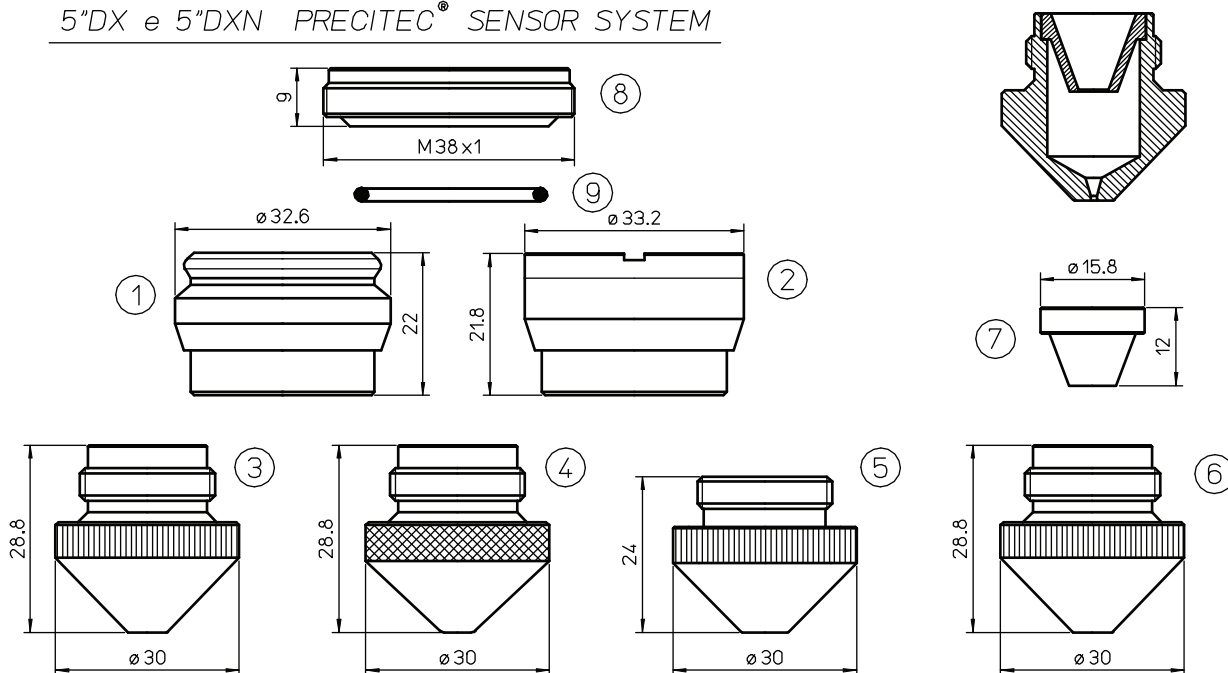

POS	II-VI p/n	OEM p/n	DESCRIPTION
1	AL35	280831-P0492-622-00002	PRECITEC® ORIG. NOZ.HOLDER KT M1.5"DX P0492-622-00002
2	AL40	280565-P0497-605-00001	PRECITEC® ORIG. NOZZLE HOLDER KT M1.5"DXN P0497-605-00001
3	L163	280029-P0492-628-00010	PRECITEC® NOZZLE Ø 1.0
	L164	280030-P0492-629-00012	PRECITEC® NOZZLE Ø 1.2
	L165	280028-P0492-627-00015	PRECITEC® NOZZLE Ø 1.5
	L166	280027-P0492-626-00020	PRECITEC® NOZZLE Ø 2.0
	L167	280026-P0492-625-00025	PRECITEC® NOZZLE Ø 2.5
	L462	281271-2.7	PRECITEC® NOZZLE Ø 2.7
	L201	280025-P0492-623-00001	PRECITEC® NOZZLE Ø 3.0
4	L887		PRECITEC® NOZZLE Ø 1.5
5	L921	281029L	PRECITEC® NOZZLE Ø 1.0
	L920		PRECITEC® NOZZLE Ø 2.0 W/COUNTER BORE
6	L259		PRECITEC® NOZZLE Ø 1.0 FOR INNER - PATENT
	L260		PRECITEC® NOZZLE Ø 1.2 FOR INNER - PATENT
	L261		PRECITEC® NOZZLE Ø 1.5 FOR INNER - PATENT
	L262		PRECITEC® NOZZLE Ø 2.0 FOR INNER - PATENT
	L263		PRECITEC® NOZZLE Ø 2.5 FOR INNER - PATENT
	L264		PRECITEC® NOZZLE Ø 3.0 FOR INNER - PATENT
7	L157		LVDD® INNER NOZZLE
8	AL201	PO492-702-00002	PRECITEC® INSULATING RING
9	AL94	71366453	AMADA® O'RING FOR NOZZLE OUTER-10 PCS

PRECITEC

All original equipment manufacturer's names, drawings, colors, trademarks and part numbers are used for identification purposes only, and we are in no way implying that any of our products are original equipment parts. All parts advertised for sale in this catalog are made for and/or by II-VI Incorporated.

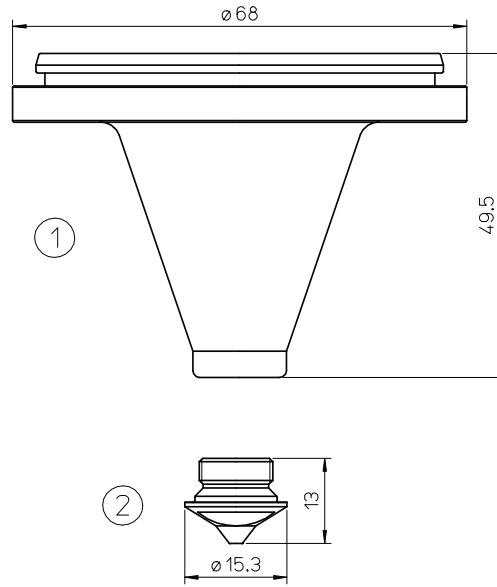

POS	II-VI p/n	OEM p/n	DESCRIPTION
1	AL244	P0587-440-00001	PRECITEC® NOZZLE HOLDER ZE SE YK Z F80 OS OUR PRODUCTION
2	L1012	P0587-842-00008	PRECITEC® NOZZLE $\phi$ 0.8
	L1013	P0587-841-00010	PRECITEC® NOZZLE $\phi$ 1.0
	L1014	P0587-846-00015	PRECITEC® NOZZLE $\phi$ 1.5

**This page intentionally left blank.**

[www.iiviinfrared.com](http://www.iiviinfrared.com)

All original equipment manufacturer's names, drawings, colors, trademarks and part numbers are used for identification purposes only, and we are in no way implying that any of our products are original equipment parts. All parts advertised for sale in this catalog are made for and/or by II-VI Incorporated.

**I-VI INFRARED** ... the world leader in CO<sub>2</sub> laser optics

**FOR ALL OF YOUR REPLACEMENT OPTIC NEEDS**

888.558.1504 (toll-free) • 724.352.1504 (phone) • 724.352.4980 (fax) • [www.iiviinfrared.com](http://www.iiviinfrared.com)

**I-VI**

The advertisement features a collection of laser optics, including several circular lenses of varying sizes and colors (yellow, orange, and green) and a black nozzle with a silver ring. The nozzle has the text "I-VI INFRARED" and "HARRISBURG, PA U.S.A." engraved on it. The background is dark, making the optics stand out.

# REPLACEMENT CO<sub>2</sub> LASER NOZZLES & ACCESSORIES

All orders received by II-VI Incorporated ("II-VI") are expressly conditioned upon the following conditions of sale:

## 1) Acceptance

Any additional or different terms set forth in any purchase order or other communication from Buyer are objected to and not binding upon II-VI unless and until accepted in writing by an authorized representative of II-VI.

## 2) Standard Warranty

II-VI warrants to the Buyer of each product of II-VI's own manufacture ("Product") that each Product will be free from defects in materials and workmanship subject to the following conditions:

The obligations of II-VI under this Standard Warranty shall be limited to either, at the option of II-VI: (1) the replacement or repair of any Product upon the shipment of such Product, freight prepaid by Buyer to the II-VI factory; or (2) the provision to Buyer of a credit against future purchases in an amount equal to the purchase price of the defective Product.

IN NO EVENT WILL II-VI BE LIABLE FOR ANY INCIDENTAL OR CONSEQUENTIAL DAMAGES OF BUYER. THE FOREGOING REMEDIES ARE THE SOLE AND EXCLUSIVE REMEDY OF BUYER FOR ANY BREACH OF WARRANTY UNDER THIS CONTRACT.

All claims under this Standard Warranty must be made within ONE (1) YEAR after the date on which the Product was delivered to Buyer. In the case of a replacement or repair of a Product, Buyer shall only ship a defective Product to II-VI after an authorized representative of II-VI has provided a Return Authorization (RA) number for such warranty claim. Returns will be subject to a 30% restocking fee.

With respect to such returns, Buyer is solely responsible for properly packaging any Product to be returned to II-VI under this Standard Warranty. Products must be packaged in their original manufacturer's packaging or equivalent. Products must be packaged in separate shipping containers with Return Authorization (RA) numbers clearly marked on the outside of the shipping containers. If there are questions regarding proper packaging and shipping, contact II-VI for guidelines. II-VI will not be responsible for replacing or repairing any Product damaged while in transit to II-VI due to faulty or deficient packaging.

This Standard Warranty shall be void and shall not apply with respect to any Product which, upon inspection by II-VI, shows evidence of damage as a result of abuse, misuse, mishandling, accidental damage, alteration, negligent handling, or improper installation or application, or as a result of alteration or other causes beyond the control of II-VI.

This Standard Warranty shall not apply to goods or parts included in or supplied with Products; such goods or parts carry only such warranties, if any, as are provided by the manufacturers of such goods or parts, which warranties may be more restrictive than the Standard Warranty provided by II-VI.

With respect to any previously-purchased Product, II-VI shall have no obligation to install updates or upgrades to any components in such Product, even if the exclusion of such updates or upgrades of such components renders such Product obsolete when compared to a new Product of a substantially similar type.

THERE ARE NO WARRANTIES THAT EXTEND BEYOND THE DESCRIPTION CONTAINED HEREIN. THIS WARRANTY VOIDS AND EXCLUDES ANY AND ALL OTHER WARRANTIES OR REPRESENTATIONS, WHETHER EXPRESS OR IMPLIED OR ARISING UNDER ANY LAW, RELATING TO THE GOODS, INCLUDING BUT NOT LIMITED TO WARRANTIES OF MERCHANTABILITY AND/OR FITNESS FOR ANY PARTICULAR PURPOSES.

NO PERSON, FIRM, OR CORPORATION IS AUTHORIZED TO ASSUME ON BEHALF OF II-VI ANY ADDITIONAL OBLIGATION OR LIABILITY NOT EXPRESSLY PROVIDED HEREIN, EXCEPT IN A WRITING DULY EXECUTED BY AN OFFICER OF II-VI.

## 3) Limitation of Liability

In no event shall II-VI be liable for any incidental or consequential damages. The liability of II-VI on any claim of any kind shall in no event exceed the price of the Product which gives rise to the claim. Except as to title, all such liability shall terminate upon expiration of the warranty period of the Product.

The invalidity of any of the previous paragraphs shall not affect the remainder of this paragraph or any other paragraph in this section.

## 4) Patent Infringement

Buyer shall hold II-VI harmless against any expense or loss resulting from infringement of patents or trademarks arising from compliance with Buyer's designs or specifications.

## 5) Delivery and Title

Delivery dates are approximate and are based upon prompt receipt of all necessary information from Buyer. Under no circumstances does II-VI guarantee date of shipment.

Unless otherwise specified by II-VI, shipment will be made and title will pass F.O.B. point of shipment. II-VI shall ship Products as it deems appropriate unless instructed otherwise in writing by Buyer.

## 6) Risk of Loss

Risk of loss or damage shall pass to Buyer upon shipment. Loss or damage that occurs during shipping by a carrier selected by Buyer is Buyer's responsibility.

## 7) Uncontrollable Delays

II-VI shall not be liable for delivery delays due to causes beyond its reasonable control including, but not limited to, acts of God, acts of Buyer, acts of military authority, governmental priorities, labor strikes, and transportation delays.

## 8) Financial Conditions

If II-VI determines in good faith that the financial condition of Buyer at any time does not justify the continuation of production or shipment on the terms of payment originally specified, II-VI may require full or partial payment in advance. In the event of Buyer bankruptcy or insolvency, II-VI shall be entitled to cancel any outstanding order and shall receive reimbursement for its cancellation charges.

## 9) Payment Terms

Unless terms are specifically set forth on the Order Acknowledgement, Buyer shall pay at such time and such terms as specified in II-VI's original invoice. Any quotations shall be valid for the period stated on the quotation.

## 10) Cancellation

Buyer may not cancel its order after shipment has been made. Buyer may cancel its order prior to shipment only upon written notice and consent of II-VI. If II-VI consents to any such cancellation, Buyer may be required to pay cancellation charges which include lost profits and all expenses incurred in connection with the cancelled order.

## 11) Jurisdiction

The validity, performance, and all matters relating to the interpretation and effect of this agreement shall be governed by the laws of the Commonwealth of Pennsylvania.

TERMS AND CONDITIONS OF SALE

All original equipment manufacturer's names, drawings, colors, trademarks and part numbers are used for identification purposes only, and we are in no way implying that any of our products are original equipment parts. All parts advertised for sale in this catalog are made for and/or by II-VI Incorporated.

**WORLDWIDE SALES OFFICES**

To place an order, contact a II-VI sales representative at any of the following locations, or log onto [www.iiviinfrared.com/contact](http://www.iiviinfrared.com/contact) for our most complete and up-to-date information.

**II-VI INFRARED**

375 SAXONBURG BLVD  
SAXONBURG, PA 16056  
UNITED STATES

888.558.1504 (toll-free in USA)  
724.352.1504 (phone)  
724.352.4980 (fax)  
[info@iiviinfrared.com](mailto:info@iiviinfrared.com) (e-mail)

**II-VI WEST**

36570 BRIGGS ROAD  
MURRIETA, CA 92563  
UNITED STATES

800.262.5273 (toll-free in USA)  
951.926.7640 (phone)  
951.926.1984 (fax)  
[info@iiviinfrared.com](mailto:info@iiviinfrared.com) (e-mail)

**II-VI BELGIUM NV**

BAAIKENSSTRAAT 21/2  
B-9240 ZELE  
BELGIUM

32 (0) 52 45 86 10 (phone)  
32 (0) 52 45 86 11 (fax)  
[sales@ii-vi.be](mailto:sales@ii-vi.be) (e-mail)

**II-VI DEUTSCHLAND GmbH**

IM TIEFEN SEE 58  
D-64293 DARMSTADT  
GERMANY

49 6151 880 629 (phone)  
49 6151 896 667 (fax)  
[info@ii-vi.de](mailto:info@ii-vi.de) (e-mail)

**II-VI SUISSE S.à.r.l.**

MOULIN-DU-CHOC  
1122 ROMANEL-SUR-MORGES  
SWITZERLAND

41 21 869 02 52 (phone)  
41 21 869 93 08 (fax)  
[info@ii-vi-suisse.ch](mailto:info@ii-vi-suisse.ch) (e-mail)

**II-VI UK LTD.**

21 BURLEY ROAD  
OAKHAM, RUTLAND  
LE15 6DH  
ENGLAND

44 1572 771 778 (phone)  
44 1572 771 779 (fax)  
[salesii-vi@oakham.uk.com](mailto:salesii-vi@oakham.uk.com) (e-mail)

**II-VI JAPAN**

WBG MARIVE EAST 17F  
2-6 NAKASE, MIHAMA-KU  
CHIBA-SHI, CHIBA 261-7117  
JAPAN

81 43297 2693 (phone)  
81 43297 3003 (fax)  
[center@ii-vi.co.jp](mailto:center@ii-vi.co.jp) (e-mail)

**II-VI SINGAPORE PTE., LTD.**

BLK. 5012, TECH PLACE II  
#04-07 & 05-07/12  
ANG MO KIO AVE. 5  
SINGAPORE 569876

65 6481 8215 (phone)  
65 6481 8702 (fax)  
[info@ii-vi.com.sg](mailto:info@ii-vi.com.sg) (e-mail)

**II-VI OPTICS (SUZHOU) CO., LTD.**

NO 12, SUTONG ROAD  
SUZHOU INDUSTRIAL PARK  
SUZHOU, CHINA 215021

86 512 6761 9295 (phone)  
86 512 6761 5049 (fax)  
[twosix@ii-vi.com.cn](mailto:twosix@ii-vi.com.cn) (e-mail)

[www.iiviinfrared.com](http://www.iiviinfrared.com)